

## Breaker/Ground Rod Driver – 25 lb (11.3 Kg)



- “D” handle and an assist handle for both vertical and horizontal operation
- Simple construction with few parts provides easy maintenance and excellent durability
- Supplied with 12" (305 mm) steel braided whip hoses
- Hydraulic cushioning of the ram return stroke helps to reduce operator fatigue
- Lever style latch for quick tool changes



HPB25

### SPECIFICATIONS

System	Open Center
Weight	25 lb (11.5 kg)
Length	22" (566 mm)
Width	6" (154 mm)
Chuck Size	7/8" x 3 1/4"
Whip Hoses	3/8" NPTF x 12" (305 mm)
Hydraulic Flow	5 – 7 gpm (19 – 25 lpm)
Operating Pressure	1,280-1,850 psi (88 – 127 bar)
Maximum Pressure	3,000 psi (207 bar)
Blows Per Minute	1,800 at 7 gpm (25 lpm)

CAT. NO.	UPC NO.	DESCRIPTION
HPB25	783310459378	Paving Breaker
 F020198K	783310417804	HTMA Male Coupler 3/8" NPTF
 F020195K	783310417774	HTMA Female Coupler 3/8" NPTF



HPB35

### Breaker – 35 lb (16 kg)

- Vibration isolated and cushioned handles to reduce operator fatigue
- Simple construction with few parts provides easy maintenance and excellent durability
- Supplied with 12" (305 mm) steel braided whip hoses
- Hydraulic cushioning of the ram return stroke helps to reduce operator fatigue
- Lever style latch for quick tool changes

#### SPECIFICATIONS

System	Open Center
Weight	35 lb (16 kg)
Length	24" (604 mm)
Width	16" (412 mm)
Chuck Size	1" x 4 1/4"
Whip Hoses	3/8" NPTF x 12" (305 mm)
Hydraulic Flow	5 – 8 gpm (19 – 30 lpm)
Operating Pressure	1,140 – 1,700 psi (78 – 118 bar)
Maximum Pressure	3,000 psi (207 bar)
Blows Per Minute	2,000 at 7 gpm (25 lpm)

CAT. NO.	UPC NO.	DESCRIPTION
HPB35	783310459385	Paving Breaker – 35 lb
F020198K	783310417804	HTMA Male Coupler 3/8" NPTF
F020195K	783310417774	HTMA Female Coupler 3/8" NPTF

## Breaker – 45 lb (20.4 kg) and 55 lb (25.2 kg)



- Great for breaking sidewalks and curbs or driving ground rod, and for other small demolition jobs
- Clean modular design with few protrusions to irritate operators' legs
- High blow energy provides maximum breaking power
- Integral rubber damper reduces chisel noise
- AVS tools have patented spring dampened handles that reduce vibration transmitted to the operator by up to 90%
- Two-step trigger
- Supplied with 12" (305 mm) steel braided whip hoses



HPB45

### SPECIFICATIONS

Accessory	F020196K HTMA Female Coupler – 1/2 in NPTF internal thread, F020197K HTMA Male Coupler – 1/2 in NPTF internal thread
Application	For Breaking Sidewalks and Curbs or Driving Ground Rod, and for other small Demolition Jobs
Blow Energy	63 ft-lb (85 J)
Blows Per Minute	2160 BPM
Handle Type	Cushioned/Spring Dampened
Length	28.5" (731 mm)
Sound Power Level	LWA=110 DB
Vibration Level	11.400 M/S <sup>2</sup> /5.300 M/S <sup>2</sup>
Weight	54 lb (24.5 kg) will vary between models

CAT. NO.	UPC NO.	DESCRIPTION
HPB45-1AVS	783310021971	Breaker – 1-1/8 x 6" tool shank size, cushioned/spring-dampened handles
HPB45-2AVS	783310021988	Breaker – 1 x 4-1/4" tool shank size, cushioned/spring-dampened handles
HPB55-1AVS	783310022015	Breaker – 1-1/8 x 6" tool shank size, cushioned/spring-dampened handles
 F020196K	783310417781	HTMA Female Coupler – 1/2" NPTF internal thread
 F020197K	783310417798	HTMA Male Coupler – 1/2" NPTF internal thread

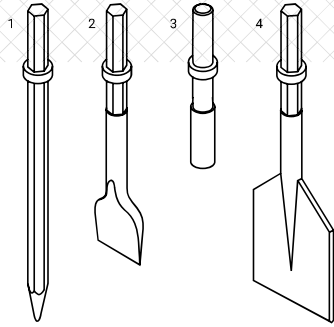

1. Moil Point  
 2. Chisel  
 3. Rod Driver Adapter  
 4. Concrete/Asphalt Cutter

### USE WITH BREAKERS

CAT. NO.	DESCRIPTION	USE WITH BREAKERS				
		25 LB (11.5 KG)	35 LB (16 KG)	45 LB (20.4 KG)		55 LB (25.2 KG)
		HPB25	HPB35	HPB45-1AVS	HPB45-2AVS	HPB55-1AVS
F016769	Moil Point – 7/8" x 3-1/4" (22 mm x 83 mm)	X	-	-	-	-
F016770K	Chisel, 3" (76 mm) – 7/8" x 3-1/4" (22 mm x 83 mm)	X	-	-	-	-
113509	Threadless Ground Rod Adapter, 1" (25 mm) 7/8" x 3-1/4" (22 mm x 83 mm)	X	-	-	-	-
137449	Threadless Ground Rod Adapter, 5/8" (16 mm) 7/8" x 3-1/4" (22 mm x 83 mm)	X	-	-	-	-
49138	Moil Point – 1" x 4-1/4" (25 mm x 108 mm)	-	X	-	X	-
46219	Chisel, 3" (76 mm) – 1" x 4-1/4" (25 mm x 108 mm)	-	X	-	X	-
46221	Asphalt Cutter, 5" (127 mm) – 1" x 4-1/4" (25 mm x 108 mm)	-	X	-	X	-
46222	Threadless Ground Rod Adapter, 5/8" (16 mm) 1" x 4-1/4" (25 mm x 108 mm)	-	X	-	X	-
46223	Threadless Ground Rod Adapter, 1" (25 mm) 1" x 4-1/4" (25 mm x 108 mm)	-	X	-	X	-
F018451	Moil Point – 1-1/8" x 6" (29 mm x 152 mm)	-	-	X	-	X
F018452	Chisel – 1-1/8" x 6" x 3" (29 mm x 152 mm x 76 mm)	-	-	X	-	X
F018453	Asphalt Cutter, 5" (127 mm) – 1-1/8" x 6" (29 mm x 152 mm)	-	-	X	-	X